

DESIGN AND DEVELOPMENT OF A TWO-MEGAWATT, HIGH SPEED PERMANENT MAGNET ALTERNATOR FOR SHIPBOARD APPLICATION

Co Huynh, Larry Hawkins, Ali Farahani, and Patrick McMullen
Calnetix Inc.
Cerritos, CA 90703

Abstract – Conventional gas turbine generator sets consist of a high speed turbine coupled to a low speed alternator through a speed reduction gearbox. This is required to maintain the alternator output frequency at 50 Hz or 60Hz, as output frequency is directly proportional to speed. Since power is also directly proportional to speed, the conventional system is bulky and possesses a very large footprint. The advent of solid-state inverters with their unique ability to efficiently and cost effectively change the alternator output frequency has made it possible to eliminate the need to link the alternator speed to the required 50/60 Hz output frequency. This output can be produced with a high-speed alternator, eliminating the need for a gearbox and greatly reducing the size, complexity, and weight of the machine by trading speed for torque. A direct drive system in which an alternator is coupled directly to a gas turbine is much more compact and highly efficient and requires much less maintenance. In this paper we will review the design and development of a high-speed permanent magnet alternator in an advanced cycle gas turbine system for shipboard applications. In addition to the alternator's design features, we will discuss design considerations including electromagnetic design, thermal design and structural design of high speed electrical machines, and review the alternator development including risk mitigation.

INTRODUCTION

The British Royal Navy has embarked on a development program to evaluate advanced cycle low power gas turbine alternator (ACL-GTA) technology as an alternative to the diesel generation (DG) system for shipboard applications. The ACL-GTA system is being considered to provide propulsion, ship's service power at sea and in harbor, and independent emergency power generation. Target platforms include future surface combatants and future carriers. ACL-GTA technology promises numerous advantages compared to DG technology including smaller foot print, environmentally compliant emissions, low maintenance, and therefore reduced manning levels. The goal of this

development program is to demonstrate the ACL-GTA system as a "diesel beating" solution, such that the ACL-GTA system should be able to compete in performance and cost with DG systems while providing the added benefits mentioned above.

The ACL-GTA system shown in Figure 1 is an integrated unit with all major components mounted on a common skid. The skid is spring mounted to reduce the shock input to the system. The major components include the gas turbine, the heat recuperator, the high speed alternator (HSA), and the electronic unit (EU) for power conditioning.

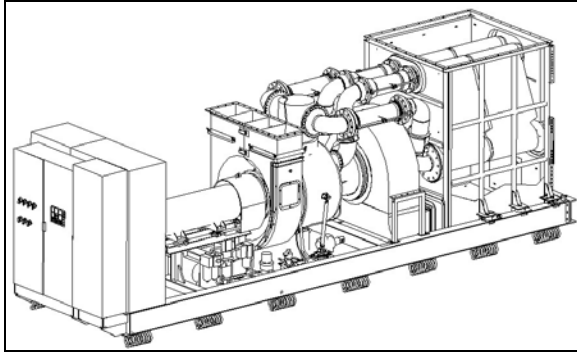

Figure 1 – ACL-GTA Configuration

The HSA couples directly to the gas turbine and operates at the same speed as the gas turbine. The use of a high-speed alternator instead of a conventional low speed synchronous machine operated through a speed reduction gearbox is one of the unique features of this ACL-GTA system. By trading speed for torque, the direct-drive turbo alternator technology provides a much more compact, highly efficient and low maintenance solution for the ACL-GTA system. This direct drive approach is further enhanced by the advent of low cost, high power semiconductor switching devices.

This paper will review the design features of the two-megawatt, permanent magnet HSA, discuss design considerations including electromagnetic design, thermal design and structural design and review the HSA development including risk mitigation.

DESCRIPTION AND UNIQUE DESIGN FEATURES

The HSA, shown in Figure 2, is a permanent magnet synchronous machine with surface mount magnets on the rotor. It couples directly to the gas turbine through a flexible mechanical coupling.

The HSA functions as a motor to provide starting torque to the gas turbine and as a generator producing electrical power as the gas turbine operates at higher running speeds. In generation mode, the HSA is designed to provide electrical output power compatible with mechanical power supplied

from the gas turbine at various speeds and ambient conditions up to rated power of 2MW. Table 1 summarizes the requirements for the HSA.

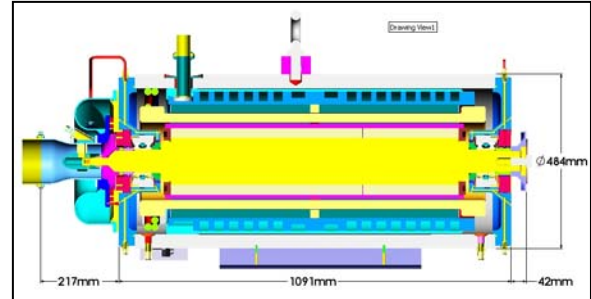

Figure 2 – HSA Configuration

The HSA is a four-pole, three-phase machine. An integral cooling fan mounted on the main rotor shaft provides cooling air for the rotor, and a liquid cooling loop in the housing cools the stator. The following describes the machine's unique design features.

Max Output Power	2030 kW
Speed Range	19krpm to 22.5 krpm
Over Speed	27krpm
Output Voltage	800Vdc @ EU output
Duty Cycle	Continuous
Ambient Condition	-20 to 55°C
Available Cooling	Water/glycol

Graphite Composite Sleeve - The high speed permanent magnet (PM) rotor utilizes a high strength graphite composite sleeve (GCS) for magnet retention. The use of graphite composite material in high speed permanent magnet machines provides some key performance advantages. Compared to a metallic sleeve, graphite composite, with its higher strength to weight ratio, is much thinner, thus resulting in better machine magnetic performance and a much more compact design. A GCS with its inherent “stranding” structure also has significantly lower rotor losses due to eddy current

effects. The disadvantages of the GCS include lower temperature rating compared to metal sleeve, negligible bending stiffness as fibers are wound in hoop direction, and very low thermal conductivity. Selection of the PM rotor configuration for this, as well as any other high speed machine application, is based on weighing these pros and cons to determine the optimal approach for each specific application. For this particular application, the advantages of graphite composite sleeve more than offset its disadvantages, as adequate air cooling is provided to cool the rotor, and rotor shaft carries adequate bending stiffness.

Integral Cooling Fan - The HSA design incorporates an integral cooling fan mounted on the same shaft as the main rotor. The integral fan provides cooling air to cool the rotor as well as buffer air for the shaft seals. The fan eliminates the need to tap off premium turbine compressor air from the system, thus optimizing system efficiency. The integral cooling fan is also much more compact when compared to an external fan as it eliminates the need for a separate support structure and drive mechanism. The primary drawback with an integral fan is the additional overhung load on the rotor that must be managed in machine's rotordynamic performance.

Split Air Cooling - One of the unique features of the air cooling scheme for the HSA is the introduction of the cooling air to the middle of the stator stack. This innovative approach significantly reduces pressure required from the fan, thus resulting in a smaller fan design and higher fan efficiency. It also reduces the air temperature gradient (inlet to outlet).

Samarium Cobalt Magnets – Consideration of different magnet materials and their contribution to the overall system

performance were part of the HSA design tradeoffs. Samarium cobalt was selected as the magnet material for this application due its higher temperature capability as well as better temperature stability and demagnetization characteristics when compared to lower cost neodymium iron boron. Although samarium cobalt has lower tensile strength, this has little effect on the retaining sleeve design since good design practice for a robust high speed rotor is to keep the magnets in compression under all operating conditions.

DESIGN CONSIDERATIONS

The design process of high-speed electrical machines involves continuous iterations of electromagnetic, thermal, structural and rotordynamic design. As depicted in Figure 3, an optimum design requires the delicate balance of all three design criteria.

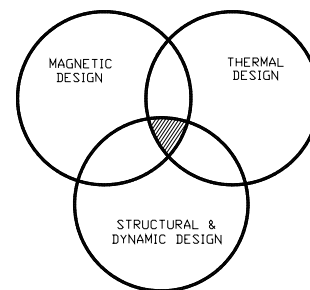

Figure 3 – HSA Design Criteria

Electromagnetic Design – Electromagnetic design is conducted using both closed form mathematical model as well as finite element (FE) method. The closed form computer model, based on permanent magnet synchronous machine theory, provides a fast and accurate tradeoff study of machine parameters such as the number of poles, stator configuration, material selection, rotor aspect ratio, etc. The FE method is utilized in conjunction with the closed form method to provide design optimization and to assist in calculating

magnetic flux leakage that is essential for accurate machine performance prediction. For a high speed design, the rotor aspect ratio (length over diameter) is one of the critical parameters and is often traded off in the EM design process. A low rotor aspect ratio has higher rotor stiffness, and is normally preferred for optimum rotordynamic performance. However, a low rotor aspect ratio requires a larger rotor diameter, thus increasing the required magnet retaining sleeve thickness and often overall machine weight. In addition, larger rotor diameter also leads to higher windage losses, lowering machine efficiency. Figure 4 shows this tradeoff of electromagnetic weight and efficiency versus rotor aspect ratio for this particular application.

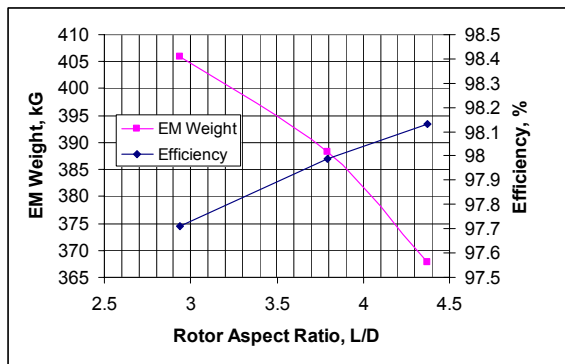

Figure 4 – EM Design Tradeoff

Thermal Design – The thermal design goal is to insure acceptable component operating temperature under all system operating conditions for optimum performance and high reliability. The critical areas for optimal thermal performance include the electrical insulation on the copper windings, the composite sleeve and the permanent magnets on the rotor. Since the gas turbine output varies significantly with speed and ambient conditions, the HSA thermal analysis examines the machine thermal performance at various speeds, loads and ambient conditions, as shown in Figure 5.

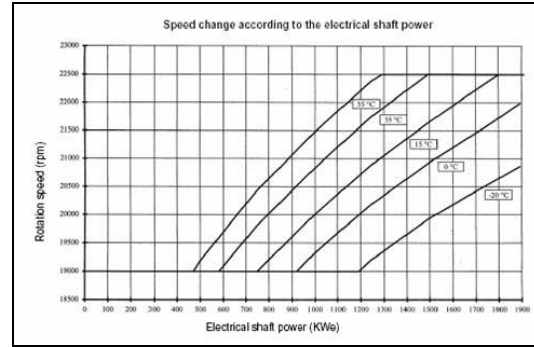

Figure 5 – Thermal Considerations

Since component operating temperatures are a function of the machine losses as well as cooling parameters, worst case component temperatures occur at maximum ambient condition rather than rated load condition for this particular design. Table 2 provides a summary of HSA thermal performance.

Critical Component	Maximum Operating Temperature,	Design Limit* for Continuous Operation
Composite Sleeve	158°C	177°C
Magnet	158°C	230°C
Winding	159°C	200°C

* Limit considers ultimate strength of material and built-in design margin based on experience

Structural Design – The structural design involved both the rotor structural integrity as well as the rotordynamic performance. For rotor structural integrity, the main focus is on the magnet retention. The finite element model of the rotor is shown in Figure 6. This model was used to establish size and minimum required thickness of the rotor sleeve. To ensure robust rotor design and reliability performance, the rotor analysis took into account all critical rotor parameters such as:

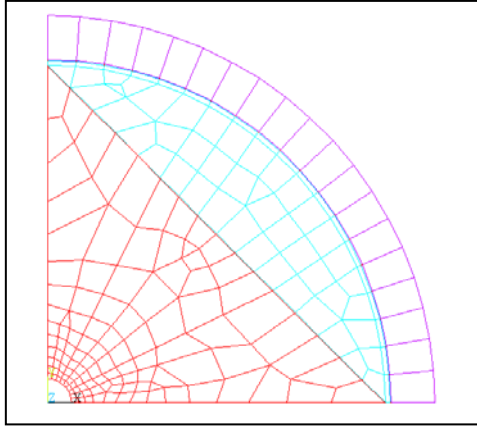

Figure 6 – Rotor FE Model

- ❑ Over-speed condition
- ❑ Operating temperature range
- ❑ Temperature distribution within the rotor (based on thermal analysis)
- ❑ Manufacturing tolerances of all rotor components

Rotordynamic analysis is used to determine the rotor natural frequencies and response to imbalance. An FEA model was built for the rotor and solved for free-free natural frequencies and mode shapes. A system dynamic model was constructed by coupling the rotor characteristics with bearing and housing characteristics using modal superposition. Figure 7 shows the damped natural frequency map with target bearing support characteristics. Both forward rotor rigid body modes are traversed at low speed (below 10,000 rpm) and there is substantial margin above the max normal operating speed of 22,500 rpm to the first rotor bending mode. Bearing loads predicted by an unbalance response analysis from one of several analyzed imbalance scenarios are shown in Figure 8. Typical synchronous bearing loads are under 400 N (90 lb) per duplex bearing pair in the 19,000 – 22,500 rpm operating range. This is with an imbalance level that is aged by a factor of 5 to account for changes to rotor balance state during long-term operation.

Desired bearing support stiffness and damping characteristics were determined using a parametric study that examined both synchronous load and displacement response and shock response. The target values of stiffness of 30.7 MN/m (175,000 lb/in) and damping of 7,900 N-s/m (45 lb-s/in) are achieved in practice by using a beam spring type support and squeeze-film damper.

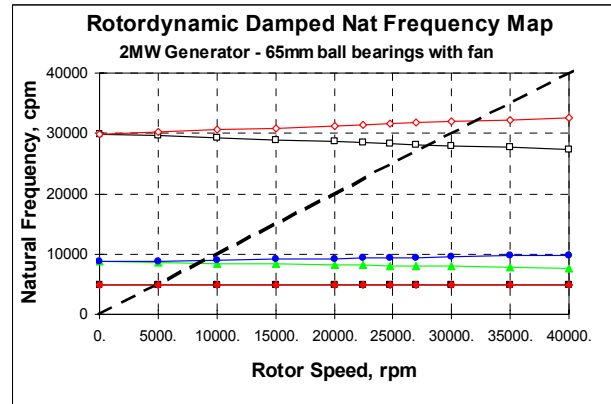

Figure 7 – Damped Natural Frequency Map

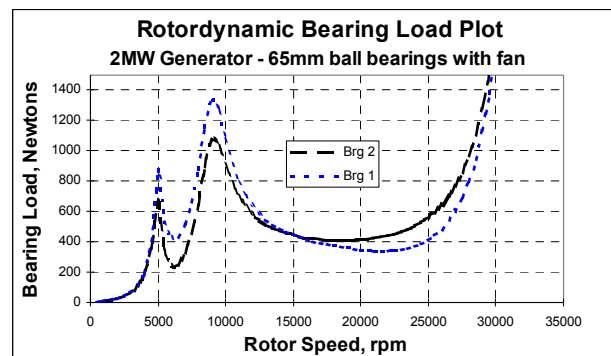

Figure 8 – Synchronous Response to Imbalance

DEVELOPMENT RISKS MITIGATION

To ensure a successful development program, major technical risks were identified early on in the program. Risk mitigation includes analyses and testing of scaled component models.

Rotor integrity – The two-megawatt PM rotor design with an outer diameter of more than 200mm is the largest PM composite

rotor design to date for operation in the 20,000 rpm range. The rotor must withstand over speed operation up to 27,000 rpm through extreme temperature conditions without significant effects on dynamic balance. To mitigate program risk, a scaled down rotor with the same diameter as the actual unit and one third of the length was fabricated in the early phase of the program. The purposes for the scaled down rotor are to demonstrate manufacturing feasibility and to verify rotor design integrity. The completed scaled down rotor was mounted vertically in a spin pit as shown in Figure 9. Subsequent testing demonstrated repeatable dynamic performance up to the over speed condition of 27,000 rpm and through extreme temperature conditions.



Figure 9 – Scaled Down Rotor Testing

Magnet Demagnetization - One major technical risk associated with permanent magnet machines is magnet demagnetization under high temperature and high electrical loading, such as a short circuit condition. Demagnetization will result in reduced field excitation from the magnets, leading to lower machine output power. Analysis can be conducted to examine magnet loading under short circuit operation, however, testing is the best approach to verify demagnetization due to the wide variation of

magnetic loading within each magnet pole and temperature effects on demagnetization. A small 4-pole PM alternator with similar rotor configuration and equivalent electrical loading was short circuit tested to measure magnet demagnetization. This testing was conducted with the unit stabilized at 180°C inside a temperature chamber, as shown in Figure 10, to simulate the high temperature operating condition. Measurement of no load voltage with the unit stabilized at room temperature before and after the short circuit test indicated insignificant changes in rotor magnetic flux.



Figure 10 – Short Circuit Testing

Internal Faults - As with all other permanent magnet machines, concerns exist that internal faults may result in a safety hazard including fire since field excitation provided by the permanent magnets in the rotor is fixed and cannot be “turned off”. Transient thermal analyses of various fault scenarios were conducted to address these concerns and to ensure a fault tolerant safe design. Two fault scenarios were considered including a balanced three-phase short circuit across zero impedance, and a line-to-line short circuit with the remaining phase connected to the load. The transient analyses took into account the emergency shutdown sequence of the gas turbine system including the coasting duration. The results shown in Figure 11 and 12 for both scenarios indicated that the HSA will not cause any

safety hazard as component operating temperatures are still within acceptable limits based on manufacturers' data and operating experience.

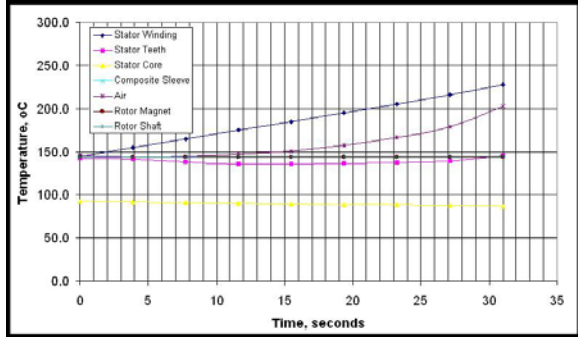

Figure 11 – Balanced 3-Phase Short Circuit

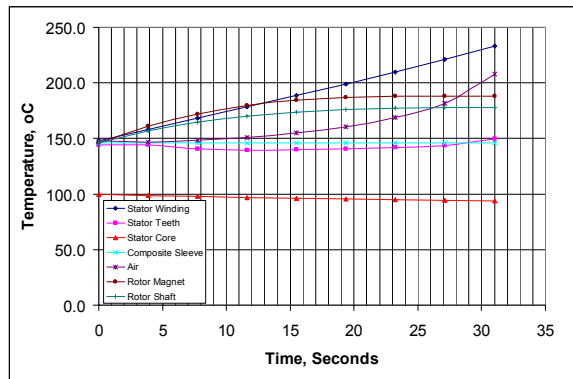

Figure 12 – Line-to-Line Short Circuit

FABRICATION AND TESTING SCHEDULE

Fabrication has been completed for the rotor assembly and all major HSA stator components. HSA integration and testing are scheduled to be completed in the first quarter of 2004.

Performance mapping of the HSA will be conducted with the unit mounted in a back-to-back test configuration in which one unit will be operated as a motor driving an identical unit functioning as a generator, or load.

CONCLUSION

The two-megawatt high speed generator offers significant cost and performance advantages compared to

competing technologies. Key performance advantages include: (1) highly efficient with an operating efficiency of 98% at rated condition, (2) small footprint for installation in a wide range of locations and applications, (3) high reliability and low maintenance, and (4) direct drive system providing simplified assembly and integration. In addition to ship board applications, this technology is also being evaluated for other commercial applications such as train, energy storage and turbo compressors.

REFERENCES

1. Development of the Advanced Cycle Low Power Gas Turbine Alternator, Ministry of Defense, British Royal Navy Presentation at 2003 ASME Conference.
2. High Speed Generators for Microturbine Applications, Energy-Tech Magazine, April 2003
3. Propulsion Full Scale Development on U.S. Navy Surface Ships, Naval Symposium on Electric Machines, October 1998
4. Design and Construction of a 75KW Scale Model of A 19MW Propulsion Motor Drive, Naval Symposium on Electric Machines, October 1998.